

Installation & Operation Instructions



Deluxe LED Spot Light

405626-3

To avoid the risk of accidents or damage to this product, it is **essential** to read these instructions **thoroughly** before this product is installed and used.

SDG Edition
June 2017

Contents

- Product Features 2**
- Specifications 2**
- Installation..... 2**
 - Spot Light Installation 3
 - Electrical Wiring.....4
 - Mounted Remote Control Installation 5
- Operation..... 6**
 - Remote Control 6
- Caution 7**
- Maintenance..... 7**
- Replacing or Adding Remote Controls.....7**
- Troubleshooting 9**
- Limited Warranty 10**

Product Features

- ⊗ Certified in compliance with IEC 60598-2-5:1998 (safety), EN 55015 + EN 61547 (CE), EN 301 489-1/-3 + EN 300 440-2 (RF), FCC Part 15B/15C (FCC), EN 60945 (marine), IP67
- ⊗ Powered by latest LED technology
- ⊗ Brighter than a 100 Watt halogen bulb, power usage as low as 54 Watts
- ⊗ 355° two speed horizontal rotation, 50° vertical range
- ⊗ Digital remote control signal reliable and resistant to interference
- ⊗ Aluminum body with corrosion-resistant coating
- ⊗ Completely sealed and waterproof
- ⊗ 12 Volts DC

Specifications

Material	Aluminum body, glass front cover	
Styling	Streamline	
Light Source	High power LED (18 LED @ 54 Watts), over-heating protection	
Light Coverage	0.25 Lux @ 2100 ft./632 m, triple spot diameter vs. 100W Halogen bulb	
Light Strength	4000 lumens	
Light Mode	Spot light	
Rotation	355° horizontal (dual speed), 50° vertical with jam protection	
Power Supply	12 VDC	
Size L x W x H	8-1/4" x 7-7/8" x 9-7/8"	21 x 20 x 25 (cm)
Weight	12 lbs./5.5 kg	
Current Draw	5 Amp	

Controls Available Separately

The spotlight comes with a 12V powered wireless remote, and a battery powered wireless remote is available **which is sold separately**, part number 405683-1. Please see our web-site at www.sea-dog.com for more details.

Installation

Tools Needed for Installation

- Electric drill
- 1/2" (12.7mm) drill bit
- Phillips head screw driver
- Crimping/cutting tool

User Supplied Items

- Four (4) ¼" (6mm) screws or four (4) ¼" bolts with nuts
- 10A fuse and fuse holder
- Two (2) #8 self-tapping screws
- Four (2) 18 – 20 gauge butt connectors

Spot Light Installation

1. The spot light should be installed on flat, level, non-metal surface.

NOTE: If the spotlight is installed on a metallic surface, there must be **at least** 1-1/4" clearance between the spotlight and the metal surface in order to allow the operation of the wireless remote (either version). See drawing #1 on page 4.

2. Use the foam gasket to mark the spotlight mounting holes and wiring access hole (1/2" /12.70mm). It is recommended that the hole pattern area be covered in masking or painter's tape to prevent spider cracking when drilling the mounting holes and the wiring access hole. See drawing #2 on page 4.
3. Route the power wires through the wiring access hole in the gasket and deck (or flat surface).
4. Ensure that the foam gasket is properly placed and sealed then fasten the spotlight to the surface using the user supplied four (4) ¼" (6mm) self-tapping screws, or the four ¼" bolts and nuts.

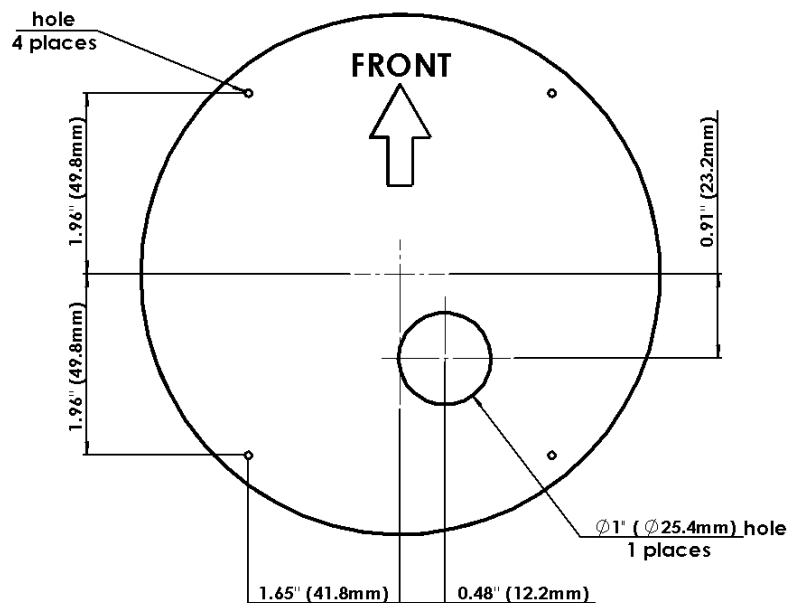

- ❗ Remember to install the foam gasket, and ensure proper sealing.
- ❗ Do not mount on metal surface; remote control will not work.
- ❗ Provide at least 1-1/4 inch (32 mm) clearance underneath the mounting surface to allow reception of remote signal. Remote control may not work if clearance is insufficient.

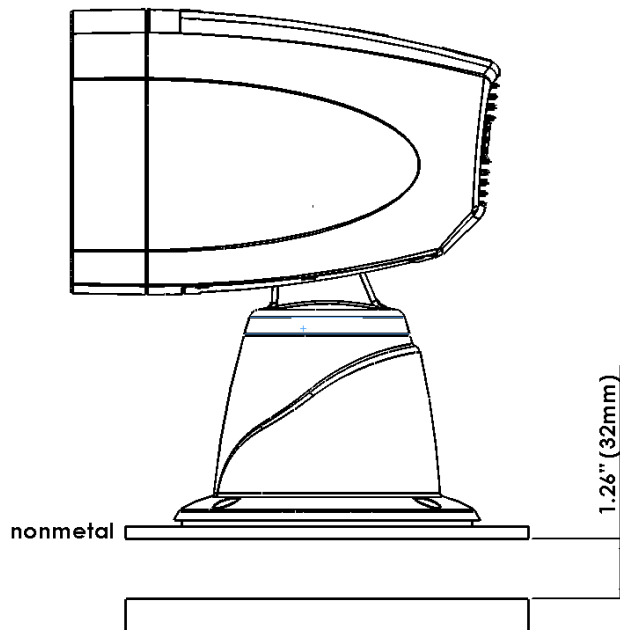

Electrical Wiring

1. Provide DC 12 Volt input power for the spotlight.
2. Protect input power positive (+) terminal with 10 A fuse or circuit breaker.
3. Use 12-gauge power cable for wiring distance not more than 30 ft. (9 m), and use 10-gauge power cable for longer wiring distance.

! Use the correct 12V power source - wrong voltage will damage product and may cause safety hazard.

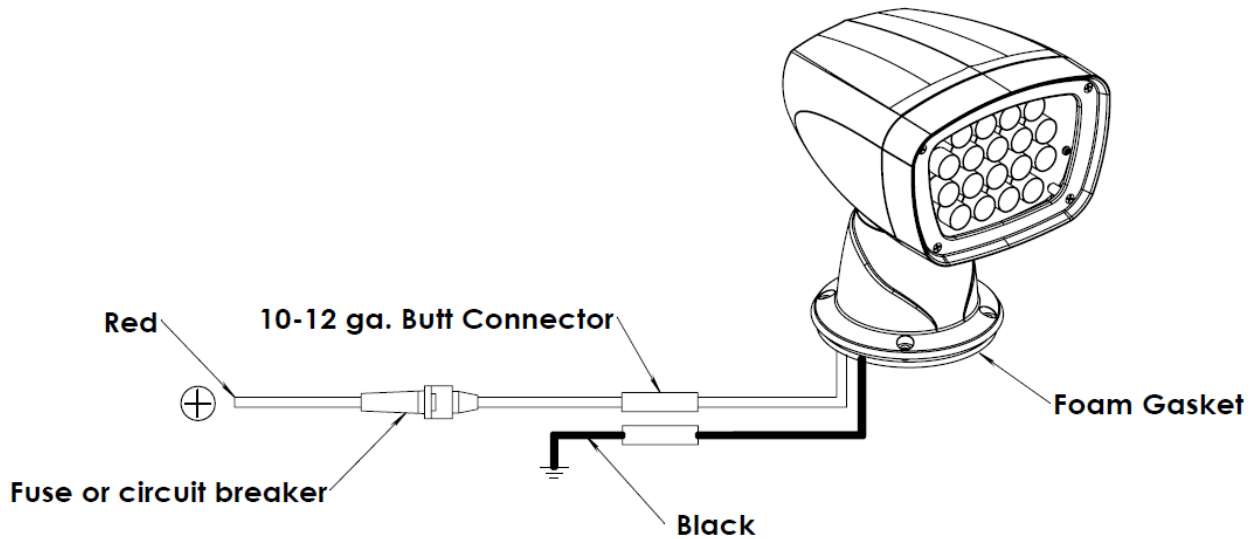

Mounted Remote Control Installation

1. The mounted remote control should be installed on flat surface in a dry or protected location.
2. Drill the wiring access hole 1/2" or 12.7mm in diameter.
3. Remove the front bezel then route the power wires through wiring access hole.
4. Secure mounted remote control by two (2) M4 self-tapping screws and replace the front bezel.

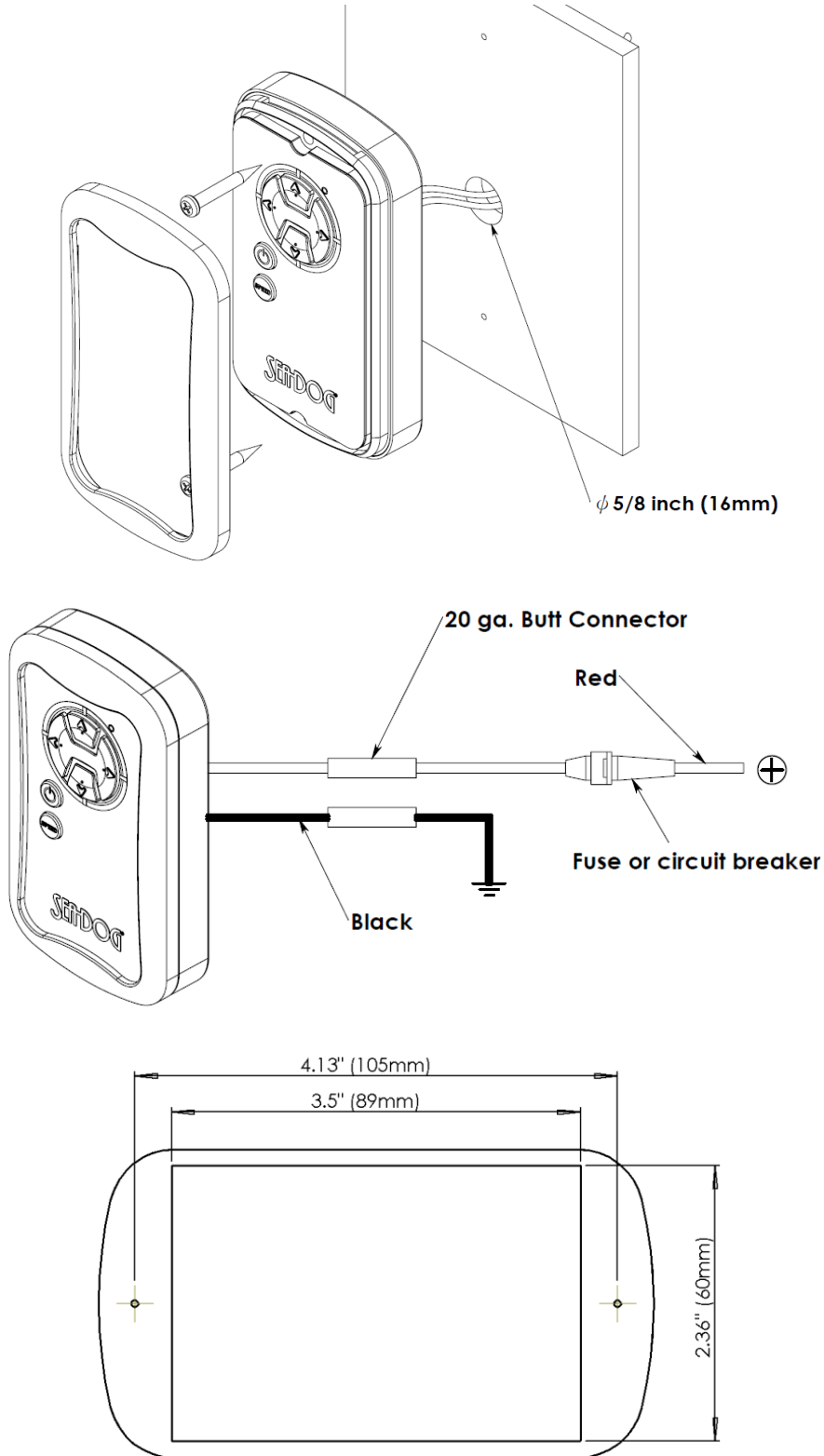

Remote Control Bracket Installation (wireless remote sold separately)

1. Take off mounting plate from the back of bracket. Secure mounting plate on selected location with the two (2) self-tapping screws that come with the product.
2. Fit bracket to mounting plate as shown in below.

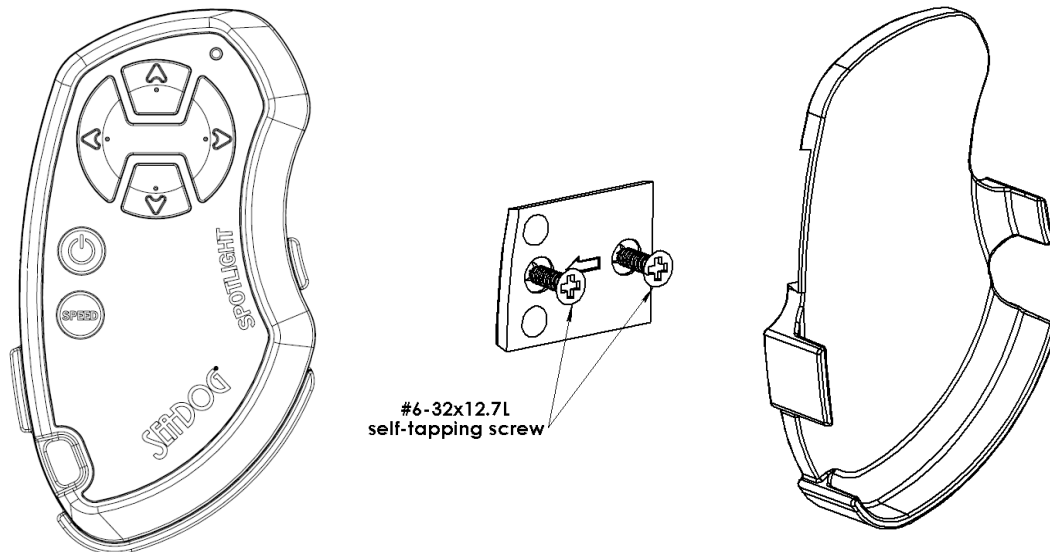

! Provide water and weather protection for the location where remote control bracket is installed.

Operation

Remote Control

1. Press arrow key to control rotation of the spot light.
2. The speed switch (see picture below) is for horizontal rotation only.
3. Same operation for wireless (battery operated) remote control sold separately.

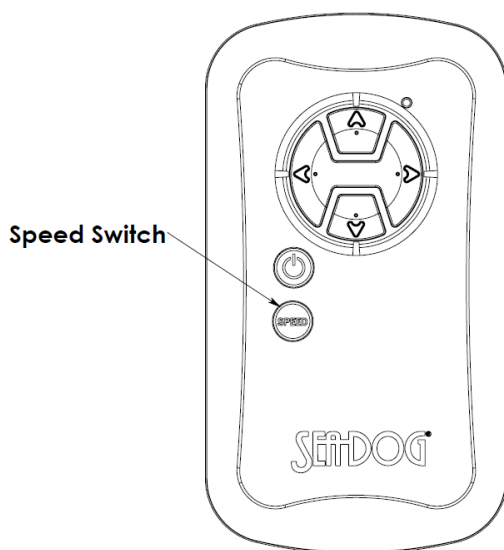

12V Powered Wireless Remote
Supplied with the Spotlight

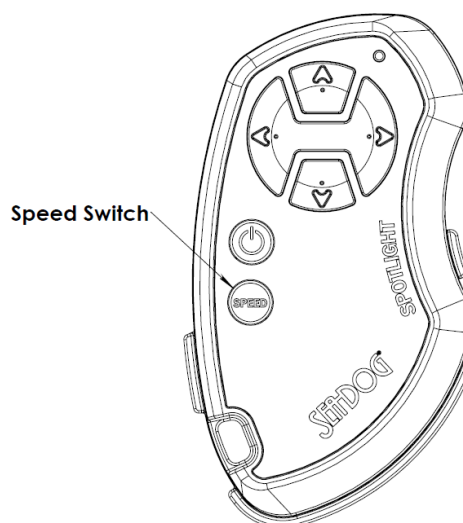

Battery Powered Wireless
Remote - Sold separately

Caution

- ❗ The 405626-3 LED spotlight has over-heating protection when left running for too long. Upon the activation of the over-heating protection system, the product will turn off 6, 12, or all 18 LED bulbs. The product will typically resume normal operation after 30 to 60 minutes. Continuous operation for more than two (2) hours should be avoided.
- ❗ **DO NOT** try to operate the product beyond angular range as it will damage the product.
- ❗ **DO NOT** press or hit the glass front cover.
- ❗ **DO NOT** look directly into the spot light while the product is in operation.
- ❗ **DO NOT** cover the light with any material, otherwise accidental activation of the product may result in fires.

Maintenance

How to conduct general care ...

1. Use diluted neutral cleanser for general cleaning.
- ❗ Do not use other chemicals or abrasives.
2. No need to provide additional lubrication.

How to replace battery for remote control ...

1. Remove remote control from bracket.
2. Loosen the two (2) screws from back cover of remote control.
3. Carefully disassemble remote control, see details in picture below.
4. Replace the used 12V / A23 battery with new one.
5. Push any button to check if the LED indicator illuminate.

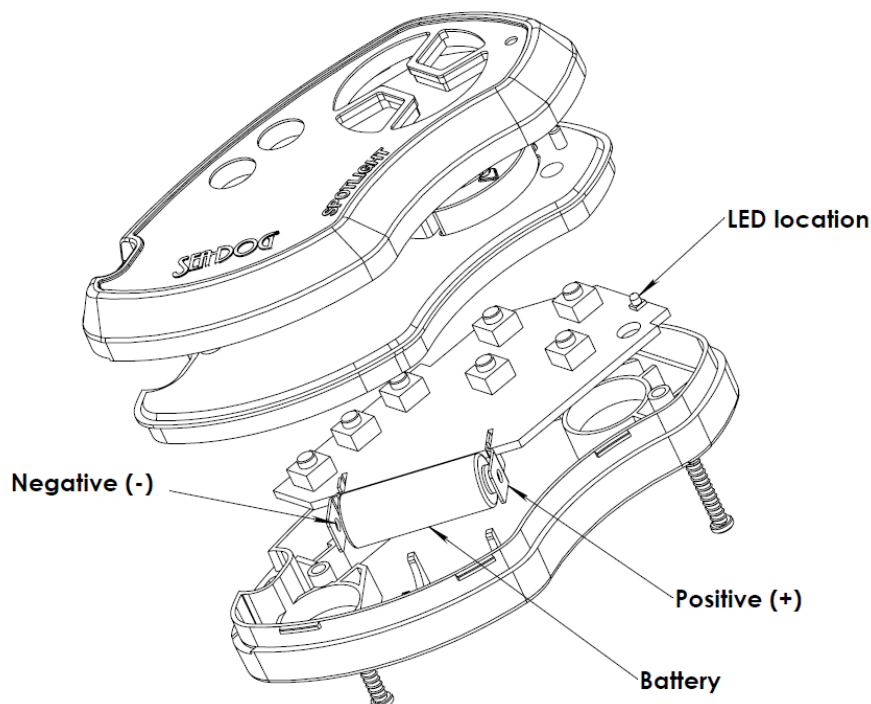

How to replace or add remote controls ...

Locate serial number in one of the following locations:

1. In case of a missing or lost remote control, user can remove the four (4) screws and take off glass front cover to obtain serial number shown on the label placed inside housing, see picture below. Note the last digit of the serial number L2XXXXXXXX (X=0~9) and then contact Sea-Dog.

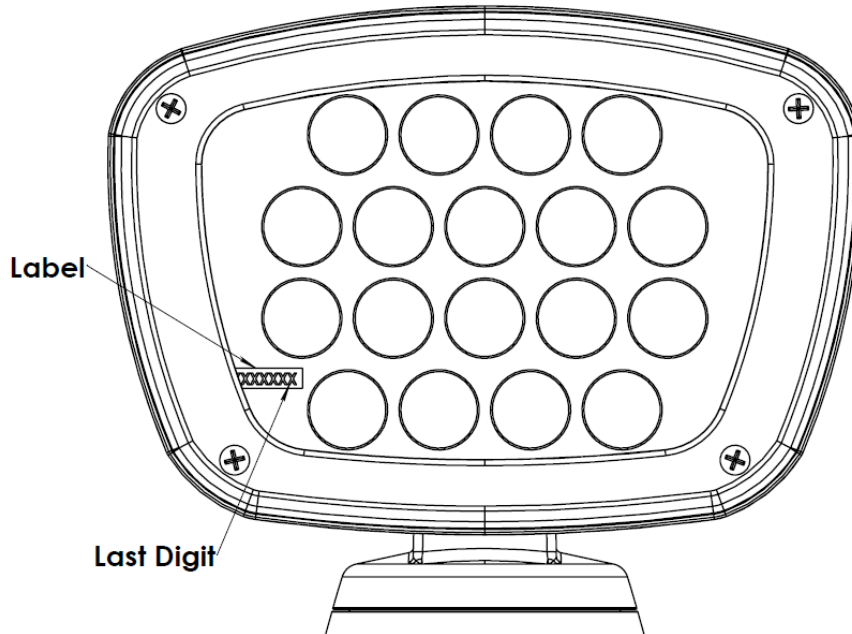

2. User can also loosen the two (2) screws from back cover of the remote control to obtain serial number shown on label R2XXXXXXXX (X=0~9). Note the last digit of serial number then notify dealer.

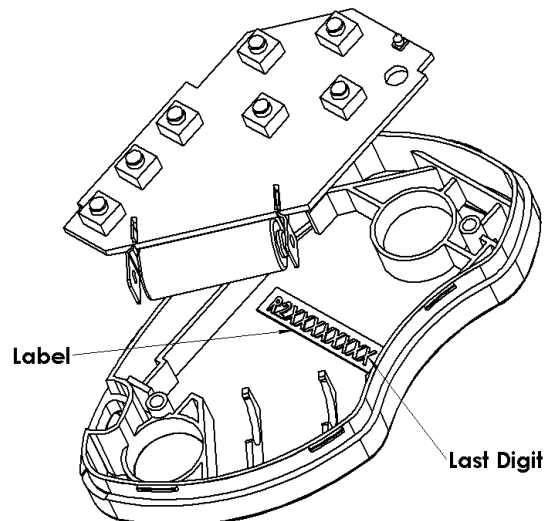

Which are replaceable parts ...

1. LED light assembly
2. LED driver
3. Controls: 12V Powered Remote Part #405693-1 (supplied)
Battery Operated Wireless Remote Part #405683-1 (sold separately).
4. Main PC board
5. Lower motor
6. Upper motor

Troubleshooting

Installation work and repairs to electrical components of this product **must** only be carried out by a suitably **qualified and competent** person in accordance with current **local and national safety regulations**. Repairs and other work by unqualified persons could be dangerous. The manufacturer cannot be held liable for unauthorized work.

What to do if ...

... the LED does not light.

- ☞ The light may be turned off by over-heating protection. Turn off power to allow the light to cool down. The light will resume normal operation after 30 to 60 minutes typically.
- ☞ Examine the LED light assembly.
- ☞ Check if the flush mount wireless remote's power connection is in good.
- ☞ Check if the wireless remote's battery is in good condition (405683-1, sold separately).

... the spot light does not respond to remote control.

- ☞ Press and hold button for 2 seconds.
- ☞ Move to a location that is less than 15 m away.
- ☞ Move to a location that has no obstructing structure between remote control and spot light.
- ☞ Make sure the light is not mounted on any metal surface and there is sufficient clearance below.
- ☞ Replace battery for remote control.
- ☞ Check whether the last digits of serial numbers inside light housing and inside remote control are identical.

... the spot light does not respond to any control.

- ☞ Check voltage of inboard battery.
- ☞ Check the fuse or circuit breaker that protects spot light and joystick control panel.
- ☞ Carefully uninstall the spot light. Examine the electrical connections and wire harness.
- ☞ Check if the flush mount wireless remote's power connection is in good.
- ☞ Check if the wireless remote's battery is in good condition (405683-1, sold separately).
- ❗ Do not replace a blown fuse until the cause of spot light malfunction is identified and resolved.
- ❗ DO NOT replace a blown fuse with a fuse that takes higher current.

... the spot light halt during operation.

- ☞ Return spot light and control to dealer for further inspection.

... the spot light cannot rotate in certain direction.

- ☞ Carefully uninstall the spot light and examine the electrical connections and wire harness.
- ☞ Replace control.

For other problems, and when problem is not solved with the above tips ...

Return complete product with proper packaging to dealer for inspection. Include a description of the problem, user contact information, and proof of purchase if requesting warranty service.

Limited Warranty

For one (5) years from the date of original purchase, Sea-Dog will, at its discretion, repair or replace for the original consumer, free of charge, any parts found defective in material or workmanship. All transportation charges under this warranty must be borne by the consumer.

Proof of purchase is required: A computerized register receipt is required. Hand-written receipts are not accepted for warranty proof of purchase. In the absence of a receipt, warranty period will be calculated from date of manufacture printed or stamped on the product.

There is no other expressed warranty. Implied warranties, including those of merchantability and fitness for a particular purpose, are limited to one (1) year from the date of purchase. This is the exclusive remedy and consequential damages are excluded where permitted by law.

This warranty does not apply if the product has been damaged by accident or misuse, or as a result of service or modification performed by an unauthorized factory. Except as otherwise expressly stated in the previous paragraph, the company makes no representation or warranty of any kind, express or implied, as to merchantability, fitness for a particular purpose, or any other matter with respect to this product. The company shall not be liable for any consequential loss to life safety and property if it's due to user's failure in following this manual to install and use the product.

Changes or modifications not expressly approved by the party responsible for compliance could void the user's authority to operate the equipment.



P.O. Box 479

Everett, WA 98206

(425) 259-0194

techserv@sea-dog.com