

Sweep Set Adjustment

1. Unscrew & Remove Shaft Plate / Remove Transmission arm

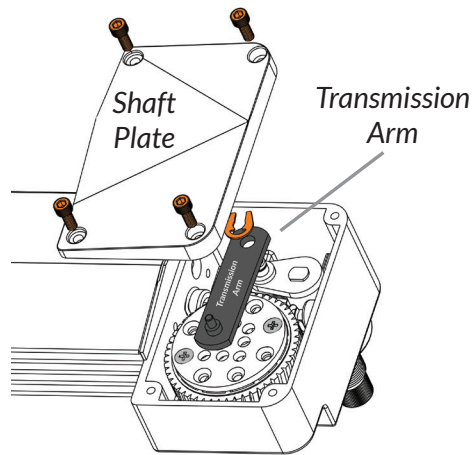

- a. Using the provided Allen wrench, remove the four screws from the shaft plate and carefully remove the shaft plate.

(Note the placement of the white o-ring in the channel in the shaft plate, which has to stay in the o-ring channel when reattaching the shaft plate to the outer motor housing.)

- b. Remove the C-clip from the end of the transmission arm using a flat blade screwdriver and lift off the **Transmission Arm** by pressing down lightly on the gear wheel to release.

(Note the location of the **oblong channel** in the white gear wheel underneath the black sweep set plate where the pin in the transmission arm is located.)

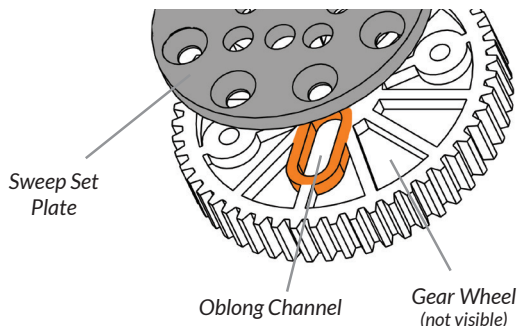

2. Adjust Sweep Set

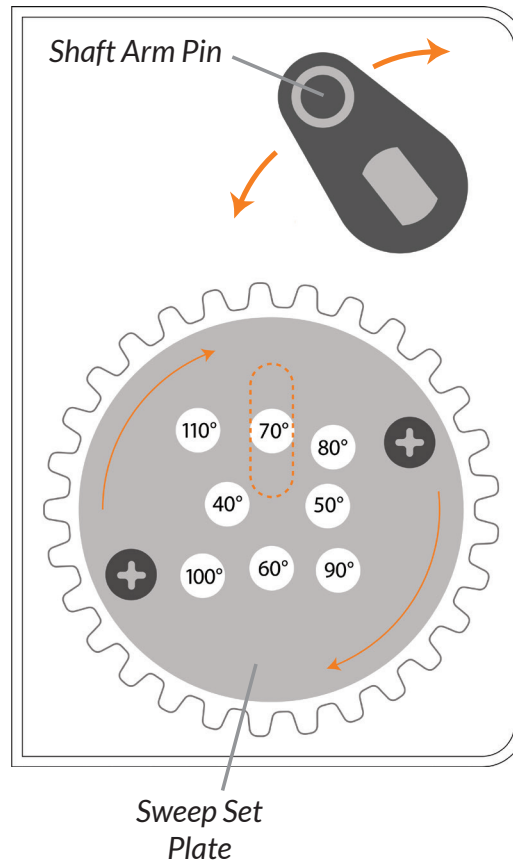

- a. Using a Phillips head screwdriver, remove the two screws holding the sweep set plate to the gear wheel and then line up the new sweep set angle hole in the sweep set plate over the **oblong channel** in the gear wheel (not visible).
- b. Replace the screws in the sweep plate.

3. Replace Shaft Plate & Fasten

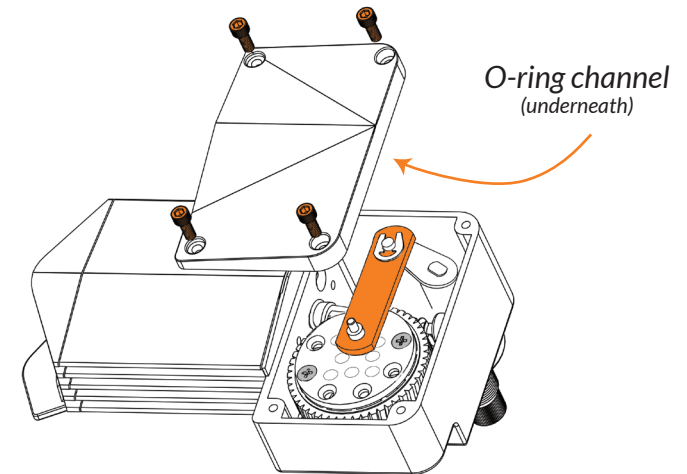

- a. Replace the **Transmission Arm**, placing the pin in the original oblong hole on one end (through the labeled sweep set hole), and onto the Shaft Arm Pin on the other.
- b. Reattach the C-clip. Put the shaft plate back on the motor and refasten the four **hex head screws**, making sure that the o-ring stays in the channel on the shaft plate.

(The o-ring must sit completely in the channel in order to maintain the motor's waterproof properties)

Left/Right Self Parking Adjustment

1. Unscrew & Remove Shaft Plate / Remove Transmission arm

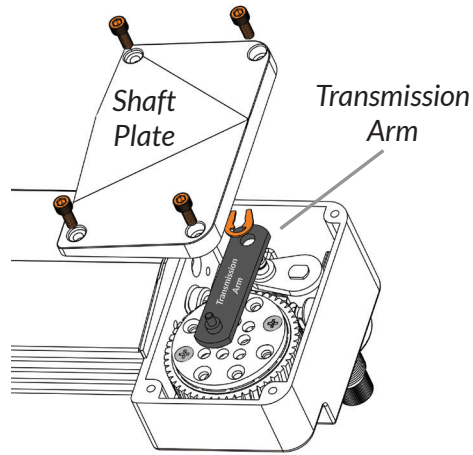

- a. Using the provided Allen wrench, remove the four screws from the shaft plate and carefully remove the shaft plate.

(Note the placement of the white o-ring in the channel in the shaft plate, which has to stay in the o-ring channel when reattaching the shaft plate to the outer motor housing.)

- b. Remove the C-clip from the end of the transmission arm using a flat blade screwdriver and lift off the **Transmission Arm** by pressing down lightly on the gear wheel to release.

(Note the location of the oblong channel in the white gear wheel underneath the black sweep set plate where the pin in the transmission arm is located.)

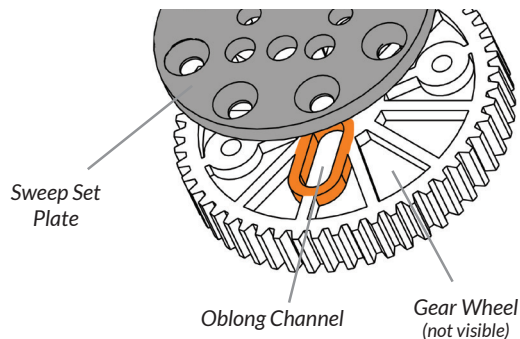

2. Adjust Sweep Set

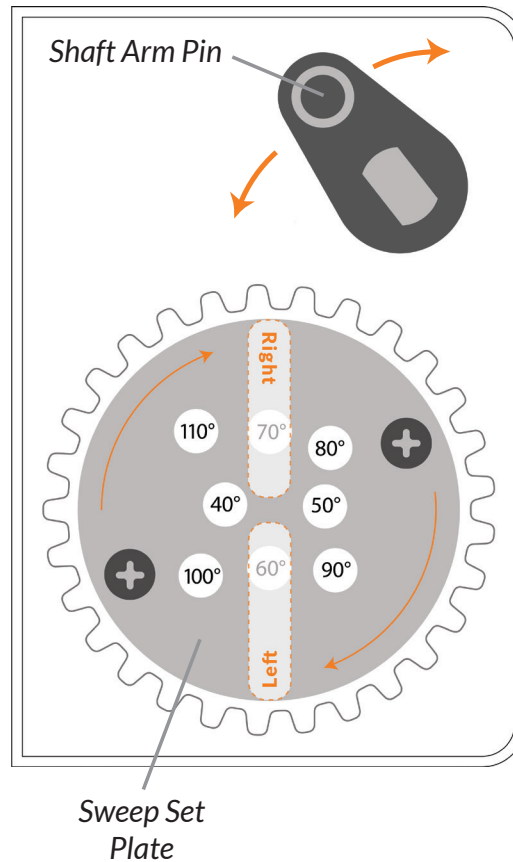

- a. Using a Phillips head screwdriver, remove the two screws holding the sweep set plate to the gear wheel and then rotate the Sweep Set Plate a full 180°, relocating the desired sweep set hole over the oblong slot on the opposite side of the wheel.

The park position is determined by facing the windshield from the outside of the boat and deciding if the motor should stop when it moves to park in the clockwise direction (right hand park) or when it moves to park in the counterclockwise direction (left hand park).

- b. Replace the screws in the sweep plate.

3. Replace Shaft Plate & Fasten

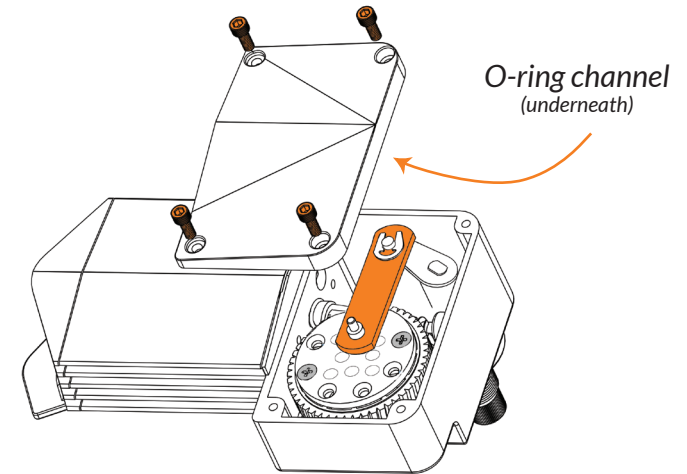

- a. Replace the **Transmission Arm**, placing the pin in the original oblong hole on one end (through the labeled sweep set hole), and onto the Shaft Arm Pin on the other.
- b. Reattach the C-clip. Put the shaft plate back on the motor and refasten the four **hex head screws**, making sure that the o-ring stays in the channel on the shaft plate.

(The o-ring must sit completely in the channel in order to maintain the motor's waterproof properties)